



REGULATIONS AND SPECIFICATIONS FOR THE **2013** KWAZULU-NATAL OFF ROAD CAR RACING CHAMPIONSHIP

MSA KWAZULU-NATAL MOTORSPORT CIRCULAR KZ 02/**2013** (158411/134)

The following are the Standing rules for the Motorsport SA KwaZulu-Natal Region Off Road Racing Championship for Cars.

1. CONTROLLERS

The controllers of this championship shall be the Motorsport SA KwaZulu-Natal Regional Motorsport Committee.

2. ELIGIBILITY OF COMPETITORS

- i) Refer Part 1 of the Off Road Racing Regulations, **2013** Motorsport SA Handbook, SSR 300
- ii) If a Competitor does not compete in a minimum of four (4) events in the season, he/she will not be eligible to win the KZN Regional Championship, or to be nominated for Regional Colours.
- iii) The championship will be open to persons normally resident in KwaZulu Natal.
- iv) Special dispensation may be applied for from MSA for certain non-KZN resident competitors to be able to compete in this championship for geographical reasons.
- v) When drivers share a drive the first nominated driver must race the prologue, to assist organizers with seeding.

3. ELIGIBILITY OF VEHICLES

Refer Part I & II of the Off Road Racing Regulations, **2013** Motorsport SA Handbook.

Note: GPS will be compulsory for regional competitors as per SSR300x

4. **2013** CHAMPIONSHIP SERIES

The Championship will comprise of the seven (7) events, six (6) of which will count towards the Championship. If due to "force majeure" only six are scored, all six will count. If five or less events are held, MSA reserves the right to withhold the declaration of a champion.

5. AIM OF THE CHAMPIONSHIP

- a) To declare a Kwazulu-Natal Off Road Car Racing Driver Champion and an overall Kwazulu-Natal Off Road Car Co-Driver Champion in Class A.
- b) To declare a Kwazulu-Natal Off Road Car Racing Driver Champion and an overall Kwazulu-Natal Off Road Car Co-Driver Champion in Class B.
- c) To declare a Kwazulu-Natal Off Road Car Racing Driver Champion in the Cricket Class.
- d) Class Points will be awarded for Class A,B and Cricket Class for each event as follows provided there are a minimum of 6 starters per class:

CLASS POINTS FOR CLASSES A, B AND CRICKET CLASS

1-25	6-10	11-5
2-19	7-9	12-4
3-15	8-8	13-3
4-12	9-7	14-2
5-11	10-6	15-1

- i) Where drivers share a drive, they will share points.
- ii) For scoring purposes a vehicle, irrespective of whether it is a twin or single seater, constitutes a starter in a particular class.

6. CLASSES AND VEHICLES SPECIFICATIONS

There will be three regional championship classes and two clubmans classes:

6.1 Regional Championship Classes:

- 6.1.1 **Class 'A'** – refer **2013** MSA Handbook, Special Vehicle Category Part II. Class P special vehicles, class D and class E production vehicles as per MSA handbook part 2 and 3 will be accommodated in this class.

6.1.2 **Class 'B'** – refer **2013** MSA Handbook, Special Vehicle Category Part II. Note: Air intake and vehicle mass will remain open.

6.1.3 **Cricket Class**

Single seater space frame – Overall Space-frame dimensions 2535mm Long x 900mm Wide +/- 2.5% x unrestricted height.

The wheelbase to be 1950mm (measured to hub centres) with front wheel track of 1426mm, and rear wheel track of 1448mm, all +/- 2.5%. (Track measured from outer face of stud plates).

Space-frame construction to conform generally to the diagram Appendix A. where only figured dimensions are mandatory. (Additional bracing bars and gussets are permitted)

Suspension – Standard A-arm configuration as supplied by Factory. Materials and tube diameters may be changed and strengthened, but geometry may not be modified from diagram Appendix B.

Each wheel with single unrestricted coil spring over double action shock absorber with maximum open length of 420mm.

Wheels – To be 12 inch of unrestricted material with 25 x 8.00 x 12 tyres

Engine – Any four stroke, air or water cooled, maximum 460cc displacement normally aspirated motor. Carburettors or fuel injection permitted.

Transmission - Two wheel drive - unrestricted.

Fuel tank – Unrestricted size. Filler cap to be offset to side opposite exhaust pipes.

Steering – Standard Rack & pinion – **dampers permitted. No power steering permitted.**

Annexures – To be read in conjunction with Appendix A and B, and to comply with all applicable MSA off-road regulations.

Note: If a vehicle is catered for in one of the above classes it WILL enter and compete in that class unless it is entered and competing in the Clubmans Classes.

6.2. **Clubmans Classes**

6.2.1 **Clubmans Class 1** – This class is open to all Non-Championship competitors in a vehicle that does not have an engine capacity greater than 2050cc, provided the crews and vehicles comply with all GCR's, SSR's and SR's applicable to Off Road Racing.

6.2.2 **Clubmans Class 2** – This class is open to all non-championship competitors in a vehicle that has an engine capacity greater than 2050cc, provided the crews and vehicles comply with all GCR's, SSR's and SR's applicable to Off Road Racing. Note: These classes will be required to run the full race distance.

6.3. All new competitors intending to enter Off Road Car Racing events, will be required to compete in the Clubman's Class for a minimum of 3 (three) events. The Specialist Off Road Committee reserves the right to review this requirement on an individual basis.

6.4. Vehicles may only change class during the year with the specific approval of the Regional Specialist Off Road Car Committee.

7. **MINIMUM DISTANCES**

The KwaZulu-Natal Championship events will be *planned* to have a minimum distance of 180 kilometres. However, in the event of inclement weather, "force majeure", etc. this minimum distance may be reduced according to circumstances. To qualify as a regional championship event the minimum distance must be greater than 100 kilometres, with the maximum distance not exceeding 300km..

8. **SEPARATION OF TIES**

As per **2013** MSA Handbook.

9. **COMPETING ORGANISERS**

A crew who intends organizing an event can elect either to compete or not in that event. Should they elect to compete in the event they will receive their finishing position points. Should the crew elect not to compete in the event they will receive points equal to the average of their best three results of the year.

Organisers points are awarded only once in a championship year.

The names of these organisers and their duties/functions on the particular event must be submitted in writing to the Regional MSA Secretary and regional MSA Off Road Car representative six weeks prior to the event, when submitting the draft regulations for that specific event.

These organisers must be "major players" in the organising of the event.

10. The championship year shall run from 01 January to 31 December of each year.

CRICKET CLASS – SPECIFICATIONS APPENDIX A

CRICKET CLASS – SPACE-FRAME SPECIFICATIONS

GENERAL CONFIGURATION – ONLY MANDATORY DIMENSIONS HAVE BEEN INDICATED HERE

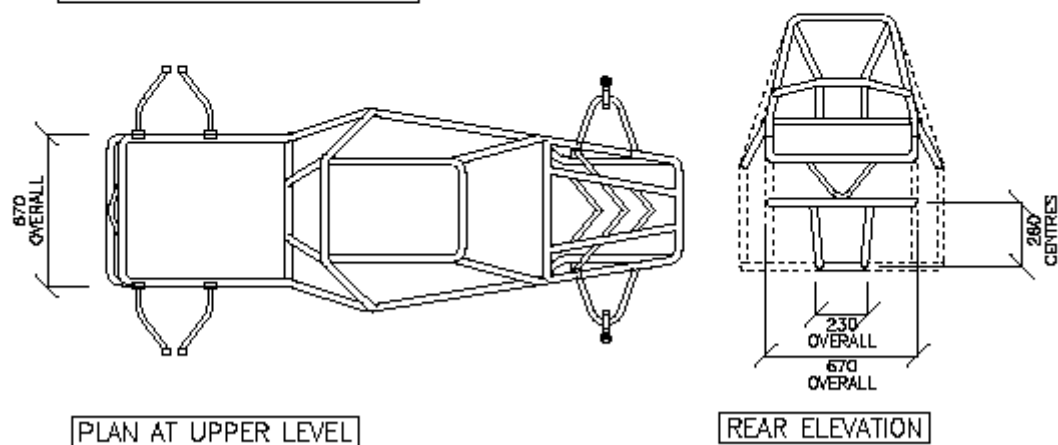
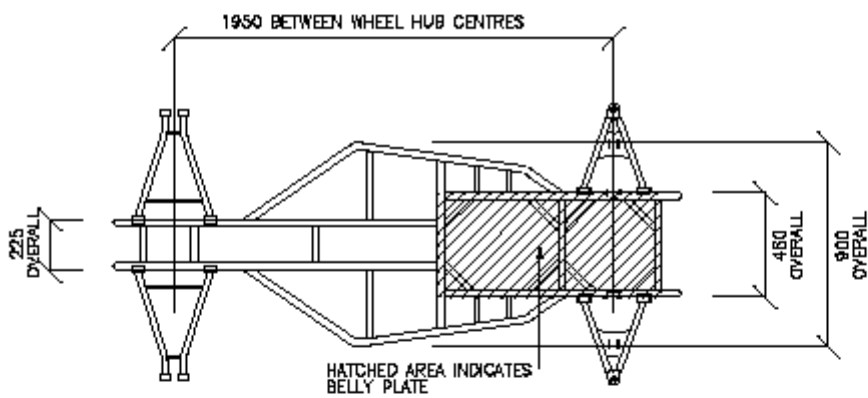
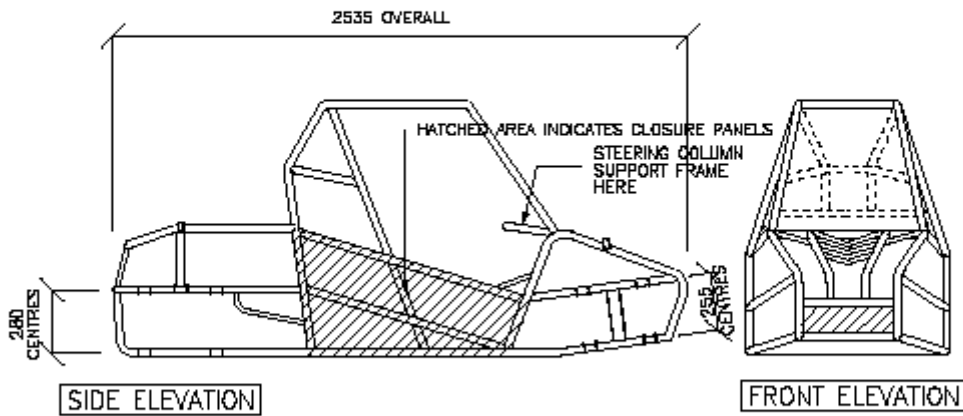

CRICKET CLASS - SPECIFICATIONS APPENDIX B

CRICKET CLASS - SUSPENSION SPECIFICATIONS

ALL DIMENSION INDICATED HERE ARE MANDATORY
 ± DIMENSIONS ARE RECOMMENDED BUT ARE DISCRETIONARY

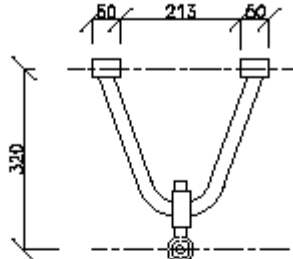

UPPER FRONT A-ARM

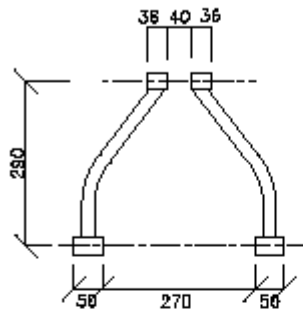

UPPER REAR SUSPENSION ARMS (TWO)

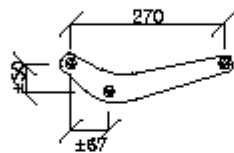

SHOCK CARRIER ARM



SHOCK CARRIER LINK

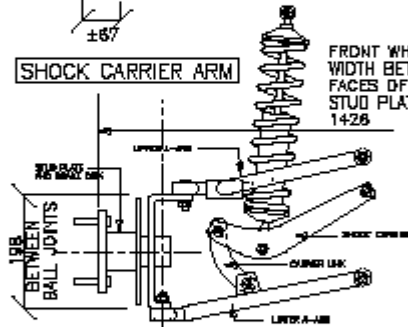

FRONT SUSPENSION CONFIGURATION

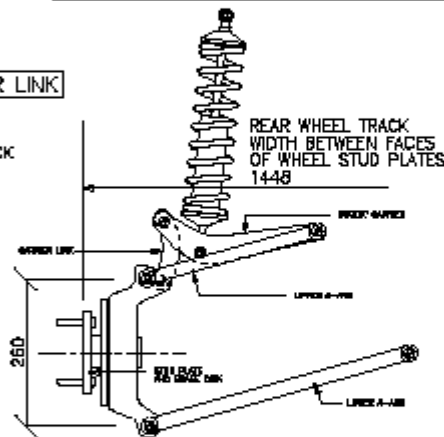

REAR SUSPENSION CONFIGURATION

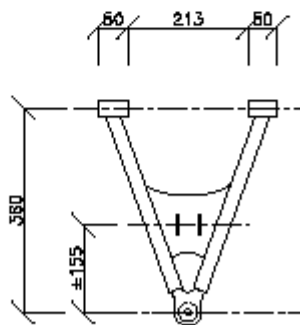

LOWER FRONT A-ARM

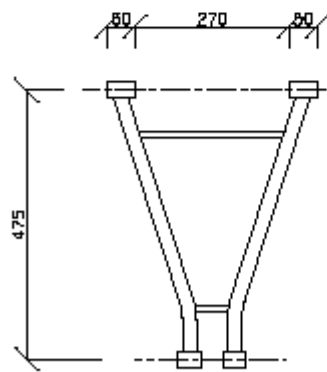

LOWER REAR A-ARM